

Bolt's worldwide leadership as a supplier of seismic energy sources has been maintained by an on-going commitment to research and development. Bolt Technology Corporation prides itself in a long tradition of service to our customers.

The company's commitment to service and excellence is demonstrated by extensive quality control procedures and tests. In addition to in-plant inspection, Bolt maintains an extensive test facility where each marine, land and bore-hole air gun is rigorously tested under conditions which simulate actual applications.



▲ Aerial View of Bolt's Test Facility

Bolt is committed to being the premiere supplier of seismic energy sources for geophysical exploration.



▲ Bubble Venting from a 9000 in³ Air Gun at 10 m. depth

Bolt Technology Corporation

Four Duke Place
Norwalk, CT 06854
Phone: (1) 203 853 0700
Fax: (1) 203 854 9601

Bolt Technology Corporation

3024 Rogerdale Road
Houston, TX 77042
Phone: (1) 713 784 8200
Fax: (1) 713 784 7158

www.bolt-technology.com
sales@bolt-technology.com



Bolt Cluster Sources

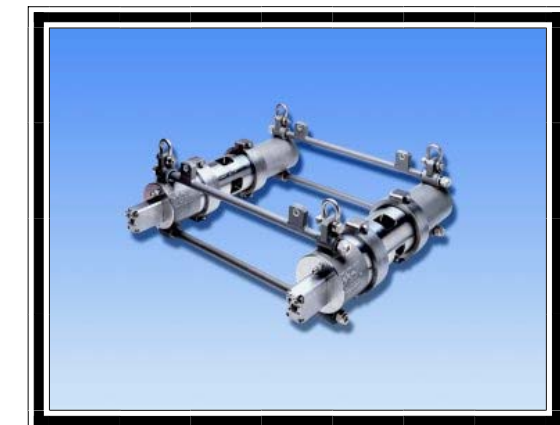
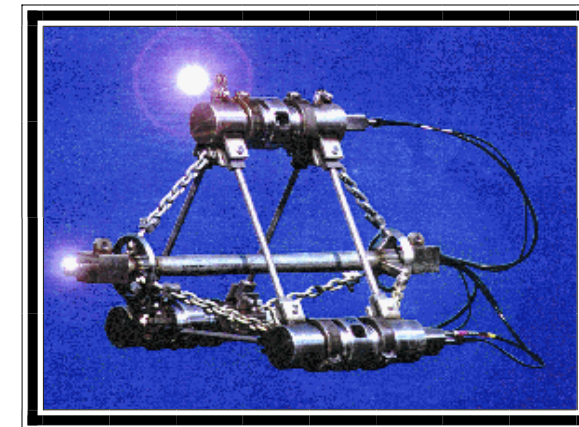

Why Cluster Air Guns?

It has become common practice in the seismic industry to configure two or more air guns together in a closely-spaced cluster to change the source signature characteristics of the air guns. In general, a cluster of air guns will have **more output** and a **higher peak-to-bubble ratio** than a single air gun of equivalent volume. The following graphs illustrate these effects.

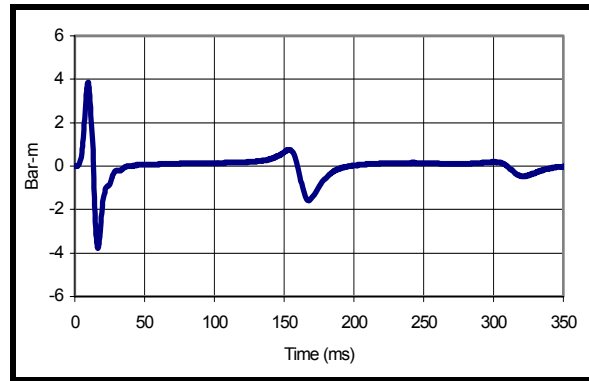

▲ Single 600 in³ Air Gun

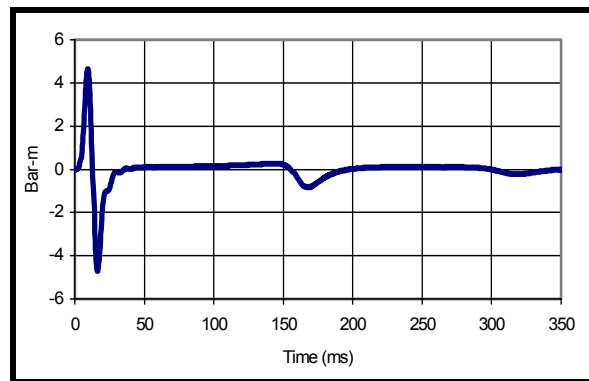

▲ 2 x 300 in³ Air Gun Cluster

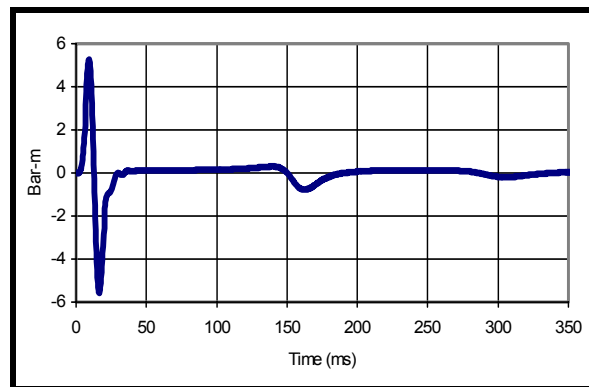

▲ 3 x 200 in³ Air Gun Cluster

The following graph illustrates the effect of separation on Peak Output and Primary-to-Bubble ratio.

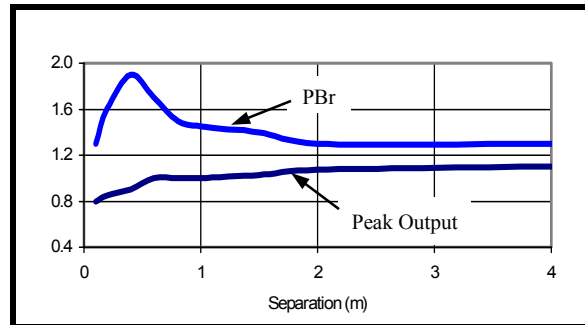

▲ Peak Output and PBr vs. Separation

The graph clearly shows Peak Output asymptotically approaching the value for two individual guns. The Peak-to-Bubble ratio has a pronounced maximum after which it also asymptotically approaches the value for an individual air gun.

Clustered vs. Single Air Guns

A two-gun cluster of air guns will have a bubble period that is shorter than the period of a single air gun with the same volume. The following graph illustrates the effect of separation on bubble period.

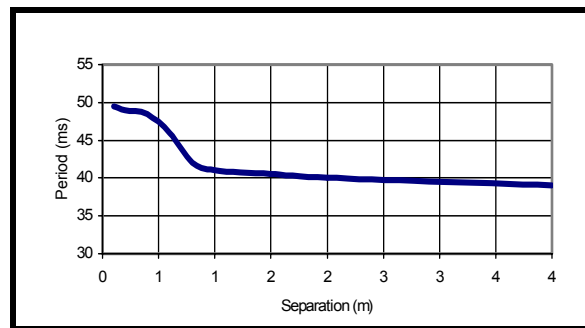

▲ Bubble Period vs. Separation

At a separation that is approximately equal to twice the equilibrium radius of the respective air gun's bubbles, the cluster is optimally configured for both peak output and peak-to-bubble ratio. When the separation is very small, the bubbles coalesce and behave as though they resulted from a single gun with a volume equal to the sum of the two guns.

When the separation is very large, the interaction between the two bubbles is minimal and the source signature is much like a signature from two separate air guns.

Air Blast and Cluster Frames

The destructive effects of the air blast associated with a discharging air gun are made worse by clustering. In order to maintain the separation between air guns within a cluster, it is necessary to mechanically constrain the air guns with rigid bars.



▲ Bolt 2-gun Cluster Frame

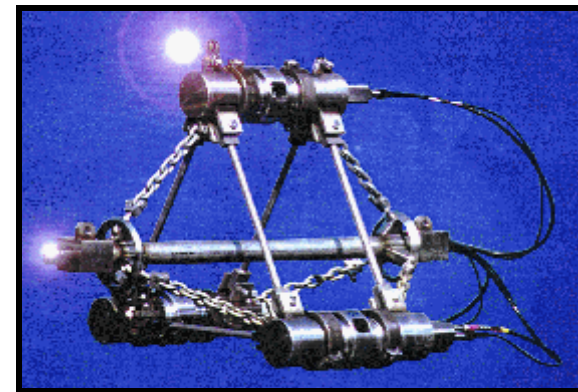

▲ Bolt 3-gun Cluster Frame

guns tend to move violently in the water, causing damage to fragile air lines and electrical connectors.

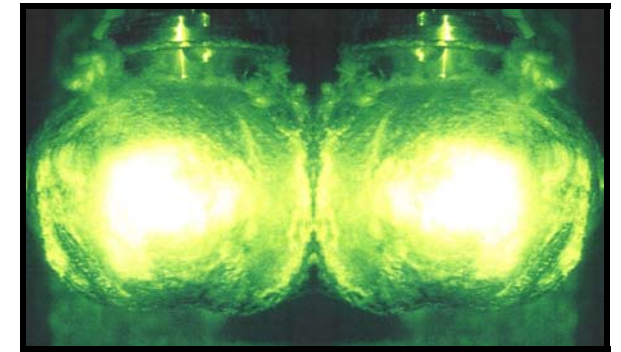

▲ Photograph of Air Gun Bubbles

(Courtesy Jan Longhammer, Martin Landro and EAGE)

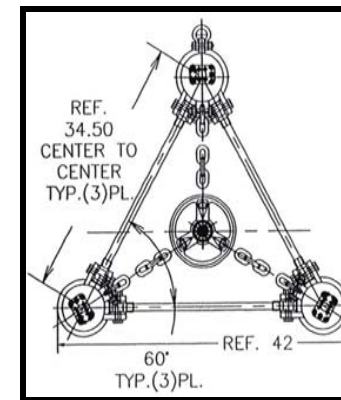

▲ 3-Gun Cluster Frame (End View)

In order to withstand the violent forces associated with clustered guns in a rigid frame, the connections within the cluster must be made of very high quality material. The symmetrical design of the 3-gun cluster assembly balances

the destructive forces associated with cluster frames. Both 2-gun and 3-gun clusters use flexible joints incorporating elastomer bushings that dissipate shock. The 3-gun cluster's central tube also provides protection to vulnerable air hose and cable jumpers.

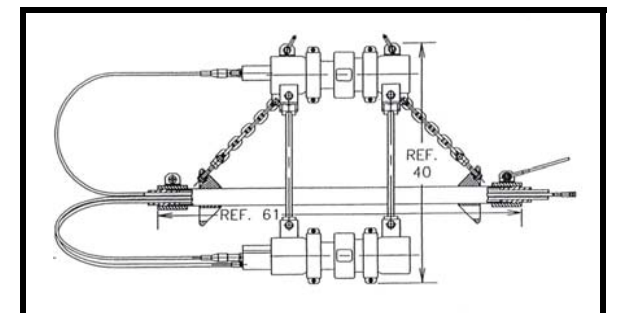

▲ 3-Gun Cluster Frame (Side View)

A single air gun generates a reasonably symmetrical air bubble which oscillates around the gun. Because the gun is suspended well away from any other gun, the oscillating bubble does not impinge upon any surface, consequently unbalanced forces from the air blast are minimized. In a cluster of air guns, the forces which result from the air blast tend to push the guns away from each other. If the guns are not constrained by means of cluster spreader bars, the